

GENERAL DESCRIPTION



The ICS874002 is a high performance Differential-to-LVDS Jitter Attenuator designed for use in PCI Express systems. In some PCI Express systems, such as those found in desktop PCs, the PCI Express clocks are generated from a low bandwidth, high phase noise PLL frequency synthesizer. In these systems, a jitter attenuator may be required to attenuate high frequency random and deterministic jitter components from the PLL synthesizer and from the system board. The ICS874002 has 3 PLL bandwidth modes: 200kHz, 400kHz, and 800kHz. The 200kHz mode will provide maximum jitter attenuation, but with higher PLL tracking skew and spread spectrum modulation from the motherboard synthesizer may be attenuated. The 400kHz provides an intermediate bandwidth that can easily track triangular spread profiles, while providing good jitter attenuation. The 800kHz bandwidth provides the best tracking skew and will pass most spread profiles, but the jitter attenuation will not be as good as the lower bandwidth modes. Because some 2.5Gb serdes have x20 multipliers while others have than x25 multipliers, the ICS874002 can be set for 1:1 mode or 5/4 multiplication mode (i.e. 100MHz input/125MHz output) using the F_SEL pin.

The ICS874002 uses IDT's 3rd Generation FemtoClock™ PLL technology to achieve the lowest possible phase noise. The device is packaged in a 20 Lead TSSOP package, making it ideal for use in space constrained applications such as PCI Express add-in cards.

BLOCK DIAGRAM

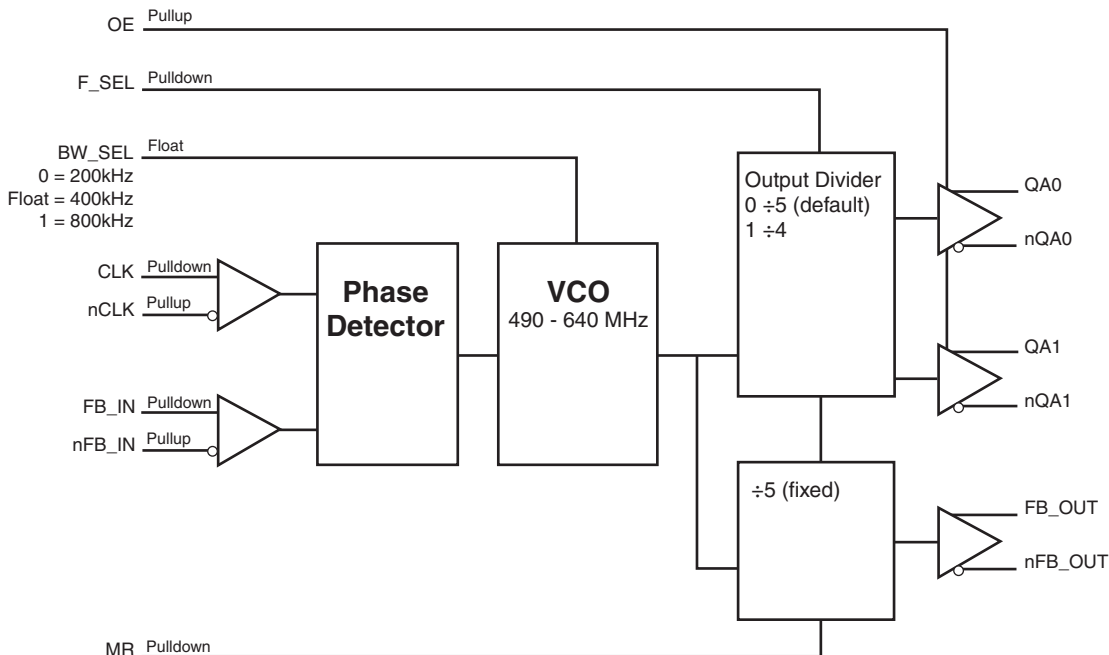

FEATURES

- Two differential LVDS output pair
- One differential clock input
- CLK and nCLK supports the following input types: LVPECL, LVDS, LVHSTL, SSTL, HCSL
- Output frequency range: 98MHz - 160MHz
- Input frequency range: 98MHz - 128MHz
- VCO range: 490MHz - 640MHz
- Cycle-to-cycle jitter: 35ps (maximum)
- 3.3V operating supply
- Three bandwidth modes allow the system designer to make jitter attenuation/tracking skew design trade-offs
- 0°C to 70°C ambient operating temperature
- Available in both standard (RoHS 5) and lead-free (RoHS 6) packages

PLL BANDWIDTH (TYPICAL)

BW_SEL
 0 = PLL Bandwidth: 200kHz
 Float = PLL Bandwidth: 400kHz (Default)
 1 = PLL Bandwidth: 800kHz

PIN ASSIGNMENT

nQA0	1	20	QA0
VDDO	2	19	VDDO
FB_OUT	3	18	QA1
nFB_OUT	4	17	nQA1
MR	5	16	nFB_IN
BW_SEL	6	15	FB_IN
nc	7	14	GND
VDDA	8	13	nCLK
F_SEL	9	12	CLK
VDD	10	11	OE

ICS874002

20-Lead TSSOP
 6.5mm x 4.4mm x 0.92mm
 package body
G Package
 Top View

TABLE 1. PIN DESCRIPTIONS

Number	Name	Type		Description
1, 20	nQA0, QA0	Output		Differential output pair. LVDS interface levels.
2, 19	V _{DDO}	Power		Output supply pins.
3, 4	FB_OUT, nFB_OUT	Output		Differential feedback output pair. LVDS interface levels.
5	MR	Input	Pulldown	Active HIGH Master Reset. When logic HIGH, the internal dividers are reset causing the true outputs (Qx, FB_OUT) to go low and the inverted outputs (nQx, nFB_OUT) to go high. When logic LOW, the internal dividers and the outputs are enabled. LVCMOS/LVTTL interface levels.
6	BW_SEL	Input	Pullup/ Pulldown	PLL Bandwidth select input. 0 = 200kHz, Float = 400kHz, 1 = 800kHz. See Table 3B.
7	nc	Unused		No connect.
8	V _{DDA}	Power		Analog supply pin.
9	F_SEL	Input	Pulldown	Frequency select pin. LVCMOS/LVTTL interface levels. See Table 3C.
10	V _{DD}	Power		Core supply pin.
11	OE	Input	Pullup	Output enable pin. When HIGH, the outputs are active. When LOW, the outputs are in a high impedance state. LVCMOS/LVTTL interface levels. See Table 3A.
12	CLK	Input	Pulldown	Non-inverting differential clock input.
13	nCLK	Input	Pullup	Inverting differential clock input.
14	GND	Power		Power supply ground.
15	FB_IN	Input	Pulldown	Non-inverting differential feedback input.
16	nFB_IN	Input	Pullup	Inverting differential feedback input.
17, 18	nQA1, QA1	Output		Differential output pair. LVDS interface levels.

NOTE: *Pullup* and *Pulldown* refer to internal input resistors. See Table 2, Pin Characteristics, for typical values.

TABLE 2. PIN CHARACTERISTICS

Symbol	Parameter	Test Conditions	Minimum	Typical	Maximum	Units
C _{IN}	Input Capacitance			4		pF
R _{PULLUP}	Input Pullup Resistor			51		kΩ
R _{PULLDOWN}	Input Pulldown Resistor			51		kΩ

TABLE 3A. OUTPUT ENABLE FUNCTION TABLE

Input	Outputs	
	QAx/nQAx	FB_OUT/nFB_OUT
0	HiZ	Enabled
1	Enabled	Enabled

TABLE 3B. PLL BANDWIDTH/PLL BYPASS CONTROL

Input	PLL Bandwidth (Typical)
BW_SEL	
0	200kHz
1	800kHz
Float	400kHz

TABLE 3C. FREQUENCY SELECT FUNCTION TABLE

Input	Outputs	
	QA[0:1]/nQA[0:1]	FB_OUT/nFB_OUT
0 (default)	÷5	÷5
1	÷4	÷5

ABSOLUTE MAXIMUM RATINGS

Supply Voltage, V_{DD}	4.6V
Inputs, V_I	-0.5V to $V_{DD} + 0.5$ V
Outputs, V_O	-0.5V to $V_{DDO} + 0.5$ V
Package Thermal Impedance, θ_{JA}	73.2°C/W (0 lfpm)
Storage Temperature, T_{STG}	-65°C to 150°C

NOTE: Stresses beyond those listed under Absolute Maximum Ratings may cause permanent damage to the device. These ratings are stress specifications only. Functional operation of product at these conditions or any conditions beyond those listed in the *DC Characteristics* or *AC Characteristics* is not implied. Exposure to absolute maximum rating conditions for extended periods may affect product reliability.

TABLE 4A. POWER SUPPLY DC CHARACTERISTICS, $V_{DD} = V_{DDA} = V_{DDO} = 3.3V \pm 5\%$, $T_A = 0^\circ\text{C}$ TO 70°C

Symbol	Parameter	Test Conditions	Minimum	Typical	Maximum	Units
V_{DD}	Core Supply Voltage		3.135	3.3	3.465	V
V_{DDA}	Analog Supply Voltage		$V_{DD} - 0.12$	3.3	3.465	V
V_{DDO}	Output Supply Voltage		3.135	3.3	3.465	V
I_{DD}	Power Supply Current				80	mA
I_{DDA}	Analog Supply Current				12	mA
I_{DDO}	Output Supply Current				110	mA

TABLE 4B. LVCMOS/LVTTL DC CHARACTERISTICS, $V_{DD} = V_{DDA} = V_{DDO} = 3.3V \pm 5\%$, $T_A = 0^\circ\text{C}$ TO 70°C

Symbol	Parameter	Test Conditions	Minimum	Typical	Maximum	Units
V_{IH}	Input High Voltage	F_SEL, OE, MR	2		$V_{DD} + 0.3$	V
		BW_SEL	$V_{DD} - 0.4$			V
V_{IL}	Input Low Voltage	F_SEL, OE, MR	-0.3		0.8	V
		BW_SEL			$V_{DD} + 0.4$	V
V_{IM}	Input Mid Voltage	BW_SEL	$V_{DD}/2 - 0.1$		$V_{DD}/2 + 0.1$	V
I_{IH}	Input High Current	OE	$V_{DD} = V_{IN} = 3.465V$		5	μA
		BW_SEL, F_SEL, MR	$V_{DD} = V_{IN} = 3.465V$		150	μA
I_{IL}	Input Low Current	OE, BW_SEL	$V_{DD} = 3.465V, V_{IN} = 0V$	-150		μA
		F_SEL, MR	$V_{DD} = 3.465V, V_{IN} = 0V$	-5		μA

TABLE 4C. DIFFERENTIAL DC CHARACTERISTICS, $V_{DD} = V_{DDA} = V_{DDO} = 3.3V \pm 5\%$, $T_A = 0^\circ\text{C}$ TO 70°C

Symbol	Parameter	Test Conditions	Minimum	Typical	Maximum	Units
I_{IH}	Input High Current	CLK, FB_IN	$V_{DD} = V_{IN} = 3.465V$		150	μA
		nCLK, nFB_IN	$V_{DD} = V_{IN} = 3.465V$	5		μA
I_{IL}	Input Low Current	CLK, FB_IN	$V_{DD} = V_{IN} = 3.465V$		150	μA
		nCLK, nFB_IN	$V_{DD} = V_{IN} = 3.465V$	-150		μA
V_{PP}	Peak-to-Peak Input Voltage		0.15		1.3	V
V_{CMR}	Common Mode Input Voltage; NOTE 1, 2		GND + 0.5		$V_{DD} - 0.85$	V

NOTE 1: Common mode voltage is defined as V_{IH} .

NOTE 2: For single ended applications, the maximum input voltage for CLK, nCLK and FB_IN, nFB_IN is $V_{DD} + 0.3V$.

TABLE 4D. LVDS DC CHARACTERISTICS, $V_{DD} = V_{DDA} = V_{DDO} = 3.3V \pm 5\%$, $T_A = 0^\circ\text{C}$ TO 70°C

Symbol	Parameter	Test Conditions	Minimum	Typical	Maximum	Units
V_{OD}	Differential Output Voltage		250	370	485	mV
ΔV_{OD}	V_{OD} Magnitude Change				50	mV
V_{OS}	Offset Voltage		1.0	1.30	1.60	V
ΔV_{OS}	V_{OS} Magnitude Change				50	mV

TABLE 5. AC CHARACTERISTICS, $V_{DD} = V_{DDA} = V_{DDO} = 3.3V \pm 5\%$, $T_A = 0^\circ\text{C}$ TO 70°C

Symbol	Parameter	Test Conditions	Minimum	Typical	Maximum	Units
f_{MAX}	Output Frequency		98		160	MHz
$f_{jit}(cc)$	Cycle-to-Cycle Jitter; NOTE 1				35	ps
$tsk(o)$	Output Skew; NOTE 2, 3				40	ps
$tsk(\emptyset)$	Static Phase Offset; NOTE 4		-150	-20	110	ps
t_R / t_F	Output Rise/Fall Time	20% to 80%	300		700	ps
odc	Output Duty Cycle		48		52	%

NOTE 1: This parameter is defined in accordance with JEDEC Standard 65.

NOTE 2: Defined as skew between outputs at the same supply voltage and with equal load conditions.

Measured at the output differential cross points.

NOTE 3: This parameter is defined in accordance with JEDEC Standard 65.

NOTE 4: Defined as the time difference between the input reference clock and the average feedback input signal when the PLL is locked and the input reference frequency is stable.

PARAMETER MEASUREMENT INFORMATION

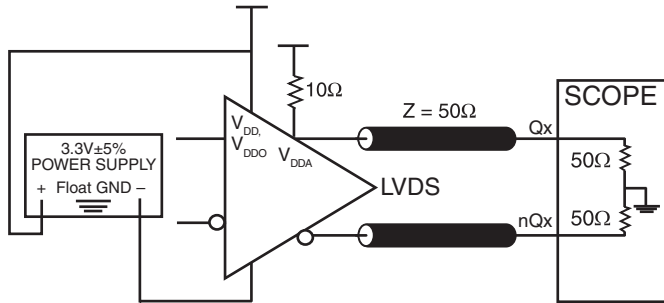

3.3V LVDS OUTPUT LOAD AC TEST CIRCUIT

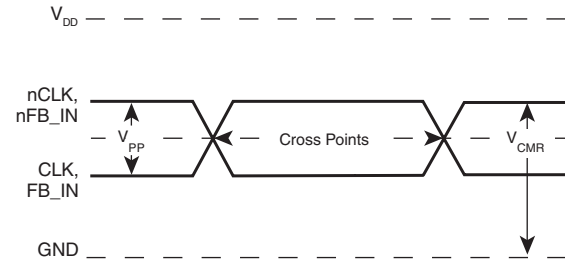

DIFFERENTIAL INPUT LEVEL

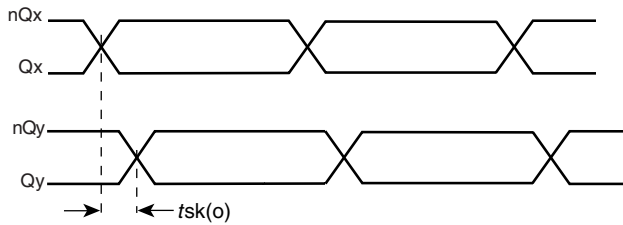

OUTPUT SKEW

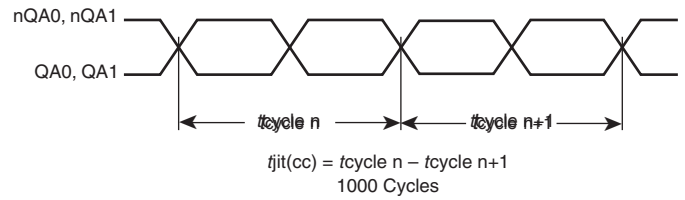

CYCLE-TO-CYCLE JITTER

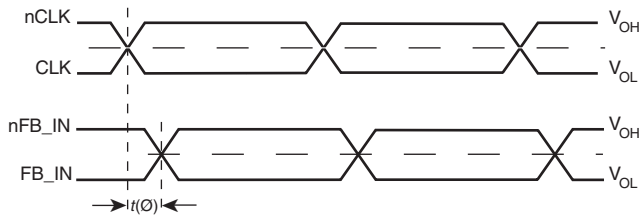

t(∅)_{mean} = Static Phase Offset

(where t(∅) is any random sample, and t(∅)_{mean} is the average of the sampled cycles measured on controlled edges)

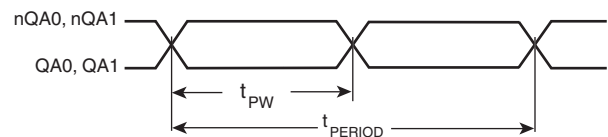

$$odc = \frac{t_{PW}}{t_{PERIOD}} \times 100\%$$

OUTPUT RISE/FALL TIME

OUTPUT DUTY CYCLE/PULSE WIDTH/PERIOD

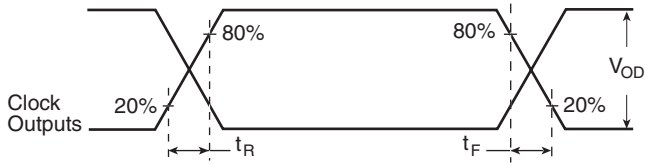

OUTPUT RISE/FALL TIME

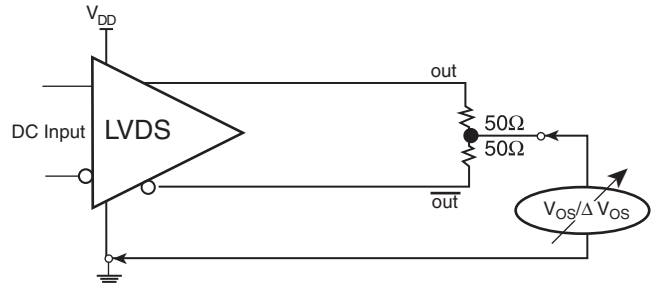

OFFSET VOLTAGE SETUP

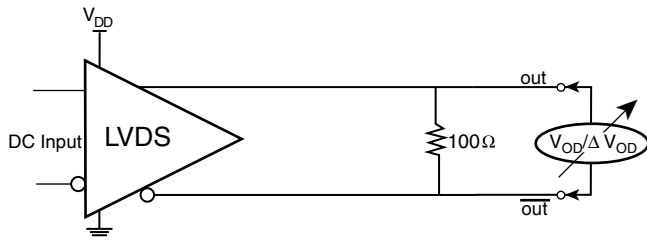

DIFFERENTIAL OUTPUT VOLTAGE SETUP

APPLICATION INFORMATION

POWER SUPPLY FILTERING TECHNIQUES

As in any high speed analog circuitry, the power supply pins are vulnerable to random noise. The ICS874002 provides separate power supplies to isolate any high switching noise from the outputs to the internal PLL. V_{DD} , V_{DDA} , and V_{DDO} should be individually connected to the power supply plane through vias, and bypass capacitors should be used for each pin. To achieve optimum jitter performance, power supply isolation is required. *Figure 1* illustrates how a 10Ω resistor along with a $10\mu\text{F}$ and a $.01\mu\text{F}$ bypass capacitor should be connected to each V_{DDA} pin.

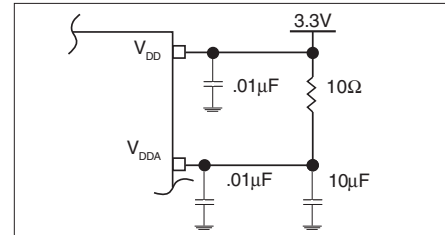

FIGURE 1. POWER SUPPLY FILTERING

WIRING THE DIFFERENTIAL INPUT TO ACCEPT SINGLE ENDED LEVELS

Figure 2 shows how the differential input can be wired to accept single ended levels. The reference voltage $V_{REF} = V_{DD}/2$ is generated by the bias resistors $R1$, $R2$ and $C1$. This bias circuit should be located as close as possible

to the input pin. The ratio of $R1$ and $R2$ might need to be adjusted to position the V_{REF} in the center of the input voltage swing. For example, if the input clock swing is only 2.5V and $V_{DD} = 3.3\text{V}$, V_{REF} should be 1.25V and $R2/R1 = 0.609$.

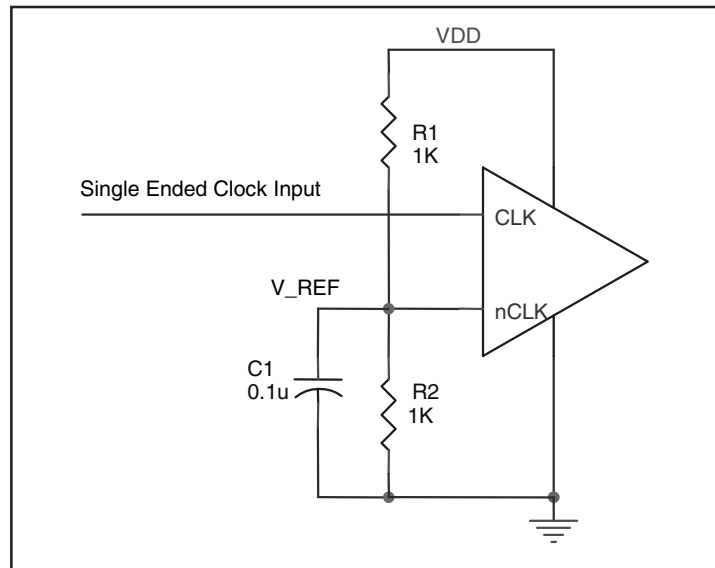

FIGURE 2. SINGLE ENDED SIGNAL DRIVING DIFFERENTIAL INPUT

DIFFERENTIAL CLOCK INPUT INTERFACE

The CLK /nCLK accepts LVDS, LVPECL, LVHSTL, SSTL, HCSL and other differential signals. Both V_{SWING} and V_{OH} must meet the V_{PP} and V_{CMR} input requirements. Figures 3A to 3D show interface examples for the HiPerClockS CLK/nCLK input driven by the most common driver types. The input interfaces suggested here

are examples only. Please consult with the vendor of the driver component to confirm the driver termination requirements. For example in *Figure 3A*, the input termination applies for IDT HiPerClockS LVHSTL drivers. If you are using an LVHSTL driver from another vendor, use their termination recommendation.

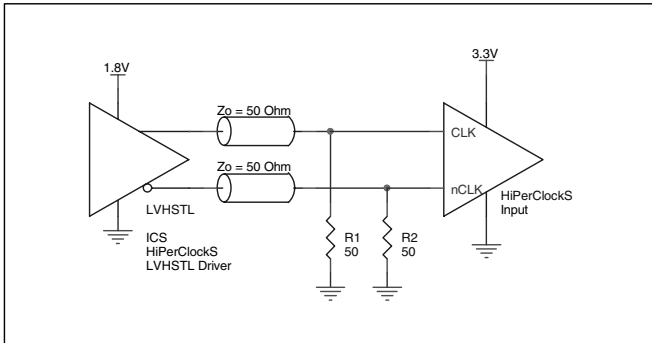

FIGURE 3A. HiPerClockS CLK/nCLK INPUT DRIVEN BY IDT HiPerClockS LVHSTL DRIVER

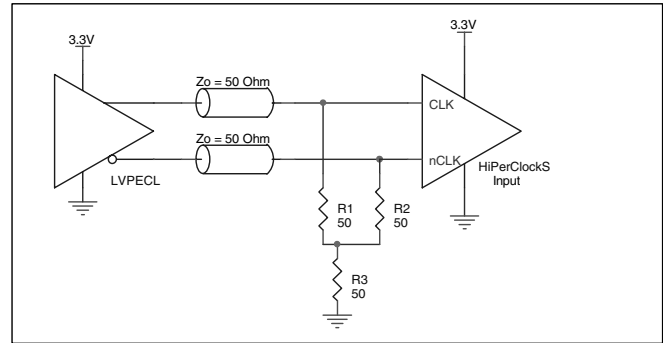

FIGURE 3B. HiPerClockS CLK/nCLK INPUT DRIVEN BY 3.3V LVPECL DRIVER

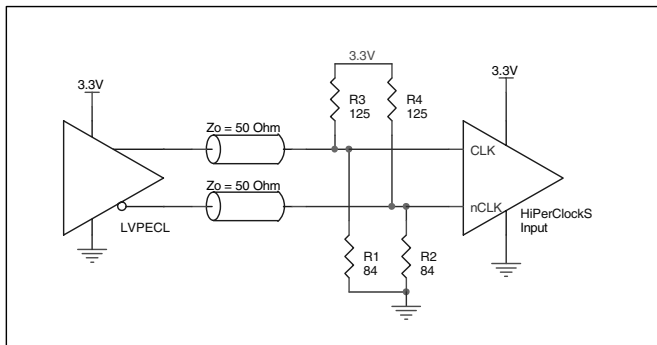

FIGURE 3C. HiPerClockS CLK/nCLK INPUT DRIVEN BY 3.3V LVPECL DRIVER

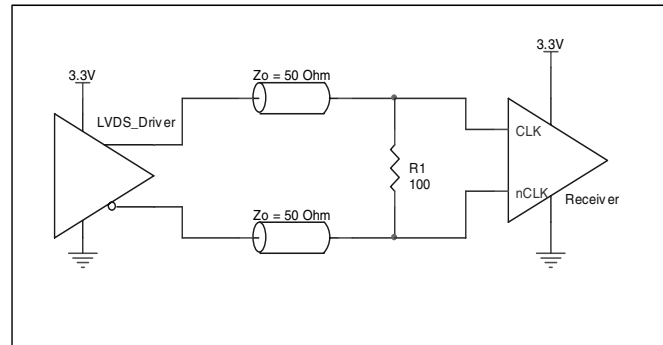

FIGURE 3D. HiPerClockS CLK/nCLK INPUT DRIVEN BY 3.3V LVDS DRIVER

RECOMMENDATIONS FOR UNUSED INPUT AND OUTPUT PINS

INPUTS:

LVC MOS CONTROL PINS:

All control pins have internal pull-ups or pull-downs; additional resistance is not required but can be added for additional protection. A 1k Ω resistor can be used.

OUTPUTS:

LVDS

All unused LVDS output pairs can be either left floating or terminated with 100 Ω across. If they are left floating, there should be no trace attached.

3.3V LVDS DRIVER TERMINATION

A general LVDS interface is shown in *Figure 4*. In a 100Ω differential transmission line environment, LVDS drivers require a matched load termination of 100Ω across near

the receiver input. For a multiple LVDS outputs buffer, if only partial outputs are used, it is recommended to terminate the unused outputs.

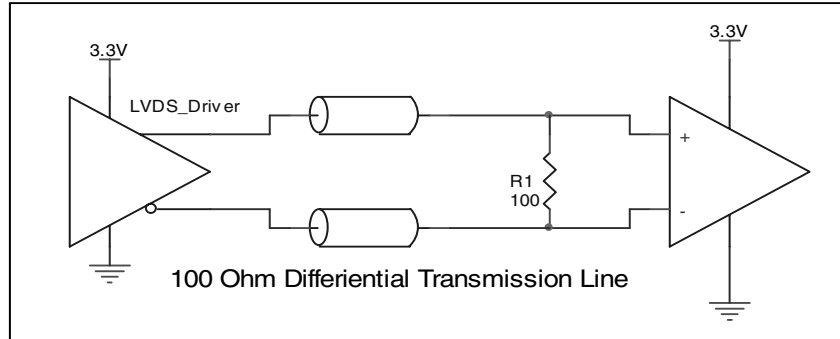

FIGURE 4. TYPICAL LVDS DRIVER TERMINATION

POWER CONSIDERATIONS

This section provides information on power dissipation and junction temperature for the ICS874002. Equations and example calculations are also provided.

1. Power Dissipation.

The total power dissipation for the ICS874002 is the sum of the core power plus the power dissipated in the load(s). The following is the power dissipation for $V_{DD} = 3.3V + 5\% = 3.465V$, which gives worst case results.

- Power (core)_{MAX} = $V_{DD_MAX} * (I_{DD_MAX} + I_{DDA_MAX}) = 3.465V * (80mA + 12mA) = \mathbf{318.78mW}$
- Power (outputs)_{MAX} = $V_{DDO_MAX} * I_{DDO_MAX} = 3.465V * 110mA = \mathbf{381.15mW}$

$$\mathbf{Total\ Power_{MAX} = 318.78mW + 381.15mW = 699.93mW}$$

2. Junction Temperature.

Junction temperature, T_j , is the temperature at the junction of the bond wire and bond pad and directly affects the reliability of the device. The maximum recommended junction temperature for HiPerClockS™ devices is 125°C.

The equation for T_j is as follows: $T_j = \theta_{JA} * Pd_total + T_A$

T_j = Junction Temperature

θ_{JA} = Junction-to-Ambient Thermal Resistance

Pd_total = Total Device Power Dissipation (example calculation is in section 1 above)

T_A = Ambient Temperature

In order to calculate junction temperature, the appropriate junction-to-ambient thermal resistance θ_{JA} must be used. Assuming a moderate air flow of 200 linear feet per minute and a multi-layer board, the appropriate value is 66.6°C/W per Table 6 below.

Therefore, T_j for an ambient temperature of 70°C with all outputs switching is:

$$70^\circ\text{C} + 0.700\text{W} * 66.6^\circ\text{C/W} = 116.6^\circ\text{C}. \text{ This is below the limit of } 125^\circ\text{C}.$$

This calculation is only an example. T_j will obviously vary depending on the number of loaded outputs, supply voltage, air flow, and the type of board (single layer or multi-layer).

TABLE 6. THERMAL RESISTANCE θ_{JA} FOR 20-LEAD TSSOP, FORCED CONVECTION

θ_{JA} by Velocity (Linear Feet per Minute)			
	0	200	500
Single-Layer PCB, JEDEC Standard Test Boards	114.5°C/W	98.0°C/W	88.0°C/W
Multi-Layer PCB, JEDEC Standard Test Boards	73.2°C/W	66.6°C/W	63.5°C/W

NOTE: Most modern PCB designs use multi-layered boards. The data in the second row pertains to most designs.

RELIABILITY INFORMATION

TABLE 7. θ_{JA} vs. AIR FLOW TABLE FOR 20 LEAD TSSOP

θ_{JA} by Velocity (Linear Feet per Minute)			
	0	200	500
Single-Layer PCB, JEDEC Standard Test Boards	114.5°C/W	98.0°C/W	88.0°C/W
Multi-Layer PCB, JEDEC Standard Test Boards	73.2°C/W	66.6°C/W	63.5°C/W

NOTE: Most modern PCB designs use multi-layered boards. The data in the second row pertains to most designs.

TRANSISTOR COUNT

The transistor count for ICS874002 is: 1216

PACKAGE OUTLINE - G SUFFIX FOR 20 LEAD TSSOP

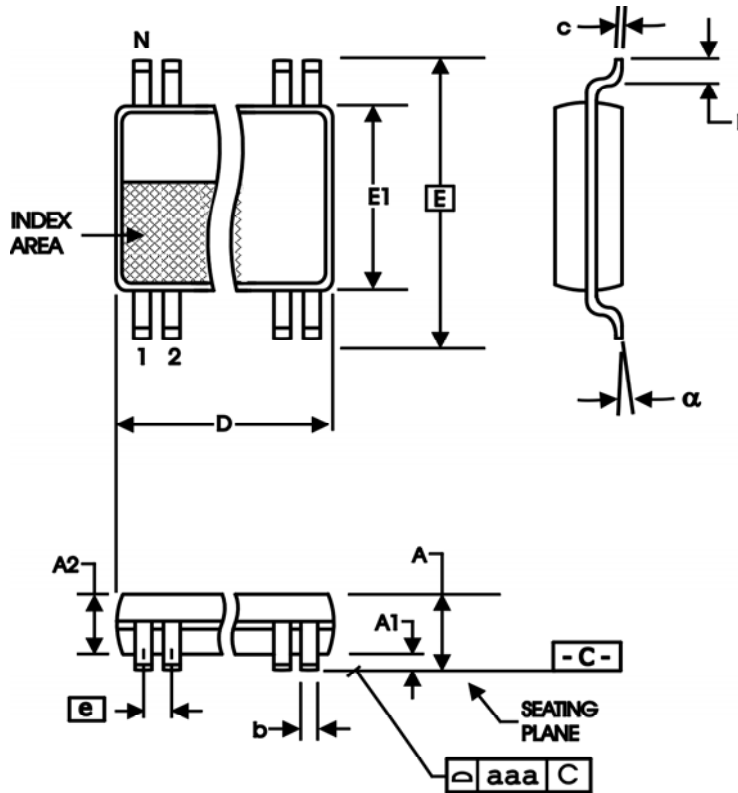

TABLE 8. PACKAGE DIMENSIONS

SYMBOL	Millimeters	
	MIN	MAX
N	20	
A	--	1.20
A1	0.05	0.15
A2	0.80	1.05
b	0.19	0.30
c	0.09	0.20
D	6.40	6.60
E	6.40 BASIC	
E1	4.30	4.50
e	0.65 BASIC	
L	0.45	0.75
alpha	0°	8°
aaa	--	0.10

Reference Document: JEDEC Publication 95, MO-153

TABLE 9. ORDERING INFORMATION

Part/Order Number	Marking	Package	Shipping Packaging	Temperature
ICS874002AG	ICS874002AG	20 Lead TSSOP	tube	0°C to 70°C
ICS874002AGT	ICS874002AG	20 Lead TSSOP	2500 tape & reel	0°C to 70°C
ICS874002AGLF	ICS874002AGL	20 Lead "Lead-Free" TSSOP	tube	0°C to 70°C
ICS874002AGLFT	ICS874002AGL	20 Lead "Lead-Free" TSSOP	2500 tape & reel	0°C to 70°C

NOTE: Parts that are ordered with an "LF" suffix to the part number are the Pb-Free configuration and are RoHS compliant.

While the information presented herein has been checked for both accuracy and reliability, Integrated Device Technology, Incorporated (IDT) assumes no responsibility for either its use or for infringement of any patents or other rights of third parties, which would result from its use. No other circuits, patents, or licenses are implied. This product is intended for use in normal commercial applications. Any other applications such as those requiring extended temperature ranges, high reliability or other extraordinary environmental requirements are not recommended without additional processing by IDT. IDT reserves the right to change any circuitry or specifications without notice. IDT does not authorize or warrant any IDT product for use in life support devices or critical medical instruments.

REVISION HISTORY SHEET

Rev	Table	Page	Description of Change	Date
A	T3C	2	Added T3C F_SEL Function Table.	12/06/06

Innovate with IDT and accelerate your future networks. Contact:

www.IDT.com

For Sales

800-345-7015
408-284-8200
Fax: 408-284-2775

For Tech Support

netcom@idt.com
480-763-2056

Corporate Headquarters

Integrated Device Technology, Inc.
6024 Silver Creek Valley Road
San Jose, CA 95138
United States
800 345 7015
+408 284 8200 (outside U.S.)

Asia Pacific and Japan

Integrated Device Technology
Singapore (1997) Pte. Ltd.
Reg. No. 199707558G
435 Orchard Road
#20-03 Wisma Atria
Singapore 238877
+65 6 887 5505

Europe

IDT Europe, Limited
321 Kingston Road
Leatherhead, Surrey
KT22 7TU
England
+44 (0) 1372 363 339
Fax: +44 (0) 1372 378851



www.IDT.com